

Design of 4-Channel Injector Cleaner and Tester Using Ultrasonic Waves

Kelvin Cahyo Arif Susanto¹ | M. Ihwanudin^{2*} | Ahmad Jainuri³

^{1,2,3} Study Program of Automotive Engineering Technology, Faculty of Vocational Studies, Universitas Negeri Malang, Malang 65145, Indonesia

Corresponding Author: M. Ihwanudin (m.ihwanudin.fv@um.ac.id)

Received: 28-08-2025 | **Accepted:** 31-08-2025

Abstract

The injector is a key component in the fuel system of a vehicle engine. If dirt or deposits accumulate, it can interfere with the fuel spraying process and reduce engine efficiency. By having their own injector cleaning tool, vehicle owners can save on the costs usually incurred for cleaning services at a repair shop. The design of the 4-channel injector cleaner and tester utilizes ultrasonic waves of the DA-968 type. Testing was conducted using the injector cleaner, ultrasonic wave device, and injector cleaner. Cleaning the injectors with the ultrasonic wave cleaner for 3-5 minutes resulted in a cloudy or dirty appearance. The injector tester was tested for 1 minute with a 5-minute cleaning cycle in the ultrasonic wave cleaner. All four injectors showed normal results with a smooth and even cone-shaped spray pattern. This study demonstrates that the 4-channel injector cleaner using ultrasonic waves of type DA-968 can be an effective and efficient solution for cleaning clogged injectors. This device can help restore engine performance to optimal conditions.

Keywords: Design, 4 Channel Injector Cleaner, Ultrasonic Waves

1. INTRODUCTION

The development of automotive technology in Indonesia is advancing rapidly in line with the high demand for transportation among the Indonesian people. Various technological advances in the transportation industry occur almost every year. Transportation allows people to move from one place to another with great ease. Transportation issues, particularly land transportation in Indonesia, are quite complex, as transportation is an interconnected system [1]. The most used modes of transportation are four-wheeled vehicles and two-wheeled vehicles. People often use two-wheeled and four-wheeled vehicles for transportation. Due to the increasing number of two-wheeled and four-wheeled vehicles, people tend to neglect maintaining and checking the quality of their vehicle engines. As a result, problems such as reduced engine power and sudden engine failure often occur.

Carburetors were originally used in fuel systems. Essentially, a carburetor is a device used to mix fuel (gasoline) with air before it enters the combustion chamber [2]. However, over time, carburetors are no longer used. The carburetor-type fuel system is now considered inefficient due to the inaccurate fuel-air mixture ratio, which results in high exhaust emissions. Therefore, with the advancement of technology, this fuel system has begun to be replaced by the fuel injection system, also known as EFI (Electronic Fuel Injection). The advantages of the EFI system include fuel savings and improved fuel-air mixture efficiency. If combustion is incomplete, fuel consumption increases, and engine performance becomes less optimal. Meanwhile, a higher-octane rating allows fuel to avoid detonation, enabling combustion to occur efficiently. The device used by the EFI system is the injector. The injector is a key component in the fuel system of a vehicle's engine. If there is a build up of dirt or deposits, it can disrupt the fuel injection process and reduce engine efficiency. Injection system damage will inevitably affect fuel efficiency since it is a vehicle component connected to the fuel system. Fuel flow is essentially restricted by a damaged injector. Other injectors will then use the remaining fuel in the tank, causing the sensor to send a signal to the ECU, resulting in inefficient fuel consumption by the vehicle. Injector leaks cause fuel wastage, while narrowing of the injector holes causes the engine to lack fuel [3]. It is time to review injector maintenance. The fact is that the vehicle will benefit greatly from this service in the ways listed below. Increased power after the injector is serviced. If acceleration feels flat at first, it may also return to normal. Thus, this injector component can also become dirty and clogged. As a result, poor fuel atomization causes its own issues with engine performance, such as causing the engine to stall or misfire [4]. The engine's fuel supply is also hindered. Consequently, after the injector is cleaned during maintenance, the previously restricted fuel flow can resume. Therefore, regular maintenance and cleaning are necessary.

Conventional injector cleaning methods use specialized tools that are typically only available at automotive workshops. This may not be practical or economical for vehicle owners to perform regular cleaning. Therefore, to clean the injector, special tools and a special fluid are required to remove the dirt adhering to the injector inlet [5]. Injector cleaner is a chemical commonly used to clean the fuel system. It is widely available on the market and relatively affordable, making it accessible for vehicle

owners to use independently. This allows vehicle owners to clean injectors themselves without having to take their vehicles to a workshop. By having their own injector cleaning tools, vehicle owners can save on costs that would otherwise be incurred for cleaning services at a workshop. They can also perform maintenance more regularly, which can extend the lifespan of the injectors [6]. By enabling vehicle owners to clean their injectors themselves, this can also promote awareness of the importance of regular maintenance for their vehicles.

2. METHOD

The methodology used in the writing and design experiment of the 4-channel injector cleaner and tester using ultrasonic waves is divided into several parts:

2.1 Injector

In essence, injectors and carburetors serve the same function: supplying fuel to the cylinders or combustion chamber. The operation of the injector is controlled by the Electronic Control Unit (ECU), enabling it to spray fuel as needed, unlike previous vehicles that relied on carburetors. The carburetor is responsible for mixing fuel and air in classic cars. This is where the injector plays a crucial role, as the fuel supply entering the combustion chamber is regulated by the injector located in the intake manifold [7].

2.2 Benefits of Injector Cleaner

To remove combustion residues from the injection component holes, use an injector cleaner. Additionally, the vehicle's fuel remains clean with the help of an injector cleaner. Restoring the engine's previous performance level. The benefits of cleaning the injector include removing carbon buildup from the engine's combustion system to ensure complete combustion, improving engine performance, making the engine lighter when accelerating, reducing fuel consumption and improving fuel efficiency, and eliminating engine knocking.

2.3 Injector Cleaner

An injector cleaner is a tool used to clean the injector components of a vehicle's engine. The benefits of an injector cleaner include removing deposits and dirt from the injector, ensuring that fuel is sprayed according to need, and improving engine efficiency and performance [8]. Although its function is the same as that of a carbon cleaner to clean injection components the injector cleaner is different from a carbon cleaner. The primary purpose of a carbon cleaner is to remove deposits that accumulate on the piston and throttle body due to combustion. Meanwhile, an injector cleaner is used to clean combustion residues expelled from the injection component holes, and it can also help maintain the cleanliness of the vehicle's fuel system.

2.4 Ultrasonic Cleaner

Regularly using an ultrasonic injector cleaner to clean dirty injectors can significantly improve engine performance and reduce fuel consumption in gasoline or diesel engines. Ultrasonic cleaning requires a vibration medium or solvent such as water or other cleaning agents, depending on the needs and type of item being cleaned, to enhance cleaning efficiency [9]. High-frequency sound waves can easily break down and remove internal deposits that clog the injector.



Figure 1. Ultrasonic Cleaner tipe DA-968

Table 1. Ultrasonic cleaner specifications

No.	System	Specifications
1.	Merk	DA-968
2.	Voltage	220V AC
3.	Power (W)	30/50 W
4.	Capacity	600 ml
5.	Dimension (L, W, H)	18.2 cm, 10.5 cm, 11.2 cm
6.	Interior Dimensions (L, W, H)	16.8 cm, 8.2 cm, 4.2 cm

The testing was conducted using an injector cleaning tool, an ultrasonic wave device, and an injector cleaner. The design of this tool involves placing the four injector components into an ultrasonic wave tank for cleaning in a highly efficient manner. Following this, the injector socket is connected to the four-channel injector component, which is already powered by a 5V DC current [10]. The testing of this device was done by observing the spray results of the injector inside the measuring cup. If the

spray results are the same, the injector is still in good condition and suitable for use. If the spray results are different from the other injectors, the injector is not suitable for use and should be replaced immediately with a new one.

Table 2. Frame Dimensions

Dimensions (cm)		
No.	Part Name	Size
1.	Length	18.2
2.	Width	10.5
3.	Height	11.2

Table 3. Interior Dimensions

Dimensions (cm)		
No.	Part Name	Size
1.	Length	16.8
2.	Width	8.2
3.	Height	6.2

2.5 Electrical Circuit Design

The first electrical system design connects 220V AC current to a 12V DC power supply. Then, from the 12V DC power supply, it goes to the fuel pump and injector components. To turn on the DA-968 ultrasonic wave device, we take electricity from 220V AC.

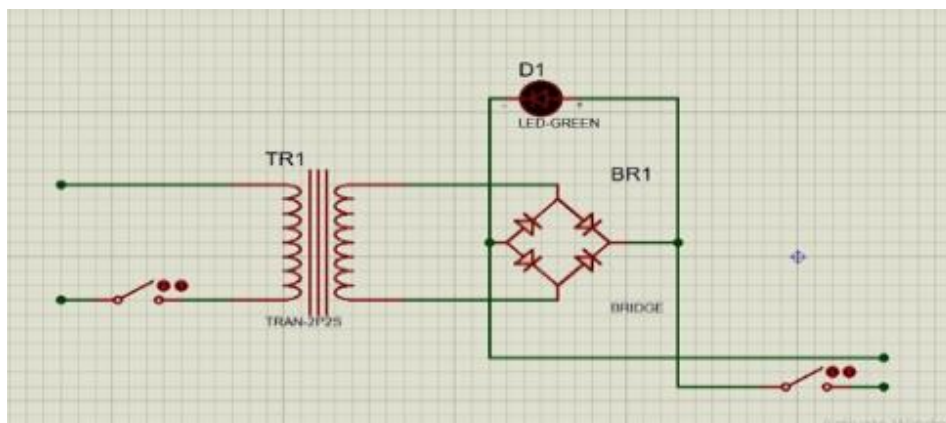

Figure 2. Electrical Wiring of Injector Cleaner

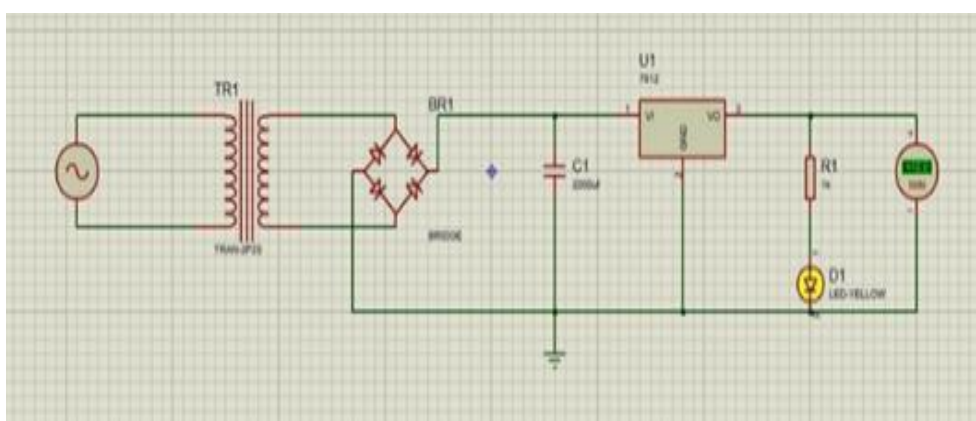

Figure 3. Electrical Wiring Power Supply for 12 Volt DC

2.1 Block Diagram

In Figure 4, the block diagram of the system consists of 4 blocks: input power supply, controller pump, injektor, and ultrasonic cleaner.

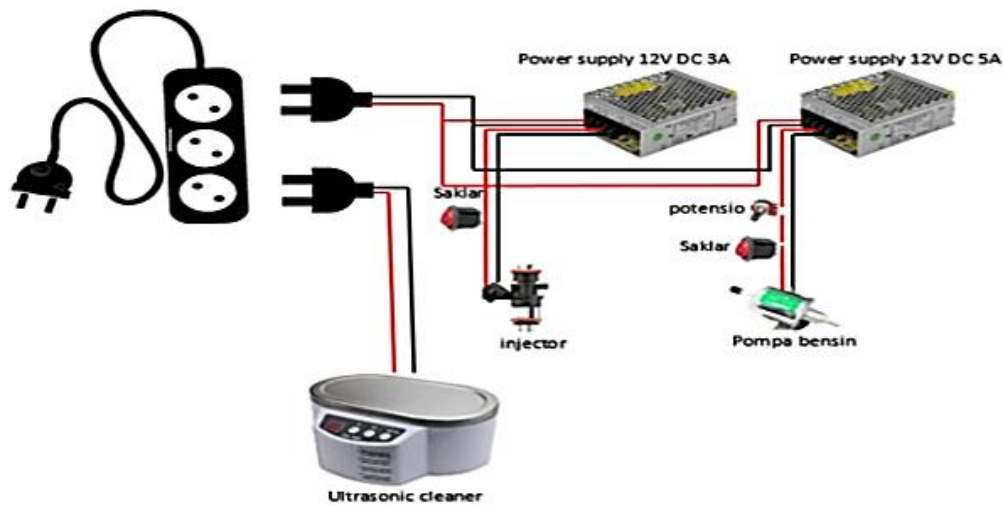

Figure 4. Electrical Wiring for Injector Cleaner

This circuit works by cleaning the injector with a special cleaning solution using ultrasonic waves operated by a power supply. Next, the injector is opened and closed using a resistor and potentiometer that have been adjusted to the cleaning requirements of the injector cleaner.

3. RESULTS AND DISCUSSION

The results of the design related to the 4-channel injector cleaner and tester using ultrasonic waves will make it easier for vehicle users to clean their injectors. By enabling vehicle owners to clean their injectors themselves, this can also encourage awareness of the importance of regular maintenance of their vehicles. This can help maintain optimal performance and minimize the potential for further damage or issues [11]. Thus, the design of the 4-channel injector cleaner and tester using ultrasonic waves of the DA-968 type aims to provide a practical and affordable solution for vehicle owners to perform injector cleaning independently, improve engine efficiency, and extend the lifespan of key components in the fuel system [12].

The testing was conducted by placing the injector components into the ultrasonic wave cleaner device, adding injector cleaner fluid into the DA-968 ultrasonic wave cleaner device as the injector cleaning fluid, and setting the ultrasonic wave cleaning time according to preference between 1-5 minutes at a power of 30-50 watts. Measurements were taken with a cleaning time of 5 minutes. Subsequently, an analysis of the accuracy of the cleaning time results obtained will be conducted [13].



Figure 5. Results of Cleaning Injectors Using Ultrasonic Waves

Table 4. Injector Cleaning Results

No.	Cleaning Time	Description
1.	3 minutes	dirty liquid
2.	5 minutes	dirty liquid

The final injector test involved designing a 4-channel injector cleaning system consisting of a main unit that can independently control the cleaning process for each channel, by supplying a 12-volt DC current to the injectors and observing the spraying of gasoline in the tube of each injector. This system must be carefully observed and measured [14].

Injector testing was conducted for 1 minute with a 3-minute cleaning cycle in an ultrasonic wave cleaner [15]. Out of the 4 injectors, 3 were found to be normal with a smooth and even cone-shaped spray, while were weak with a smooth cone-shaped spray [16].

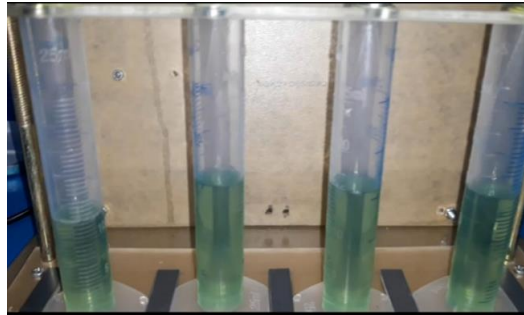

Figure 6. Injector Tester Results

Testing the injector tester for 1 minute with 5 minutes of cleaning in an ultrasonic wave cleaner, all 4 injectors were found to be normal with a smooth and even cone-shaped spray.

Table 5. Injector Cleaning Results

No	Level	Cleaning time	Rhythm	Volume (mm)
1.	25 mm	1 minute	Fast	15 mm
2.	25 mm	1 minute	Moderate	10 mm

The design of the 4-channel injector cleaner and tester using ultrasonic waves considers the ease of cleaning injectors independently by vehicle owners. Independent injector cleaning can be done using commercially available cleaning tools and materials or those that can be made yourself. This can save money compared to taking the vehicle to a repair shop for cleaning. Although the process of cleaning injectors independently requires time and effort, users have the flexibility to adjust the cleaning schedule according to their needs. This can save time because there is no need to go to a repair shop and wait for the cleaning to be completed. Cleaning injectors independently allows users to make it part of their vehicle maintenance routine. By cleaning regularly, they can extend the life of the injectors and keep the vehicle's engine performance in optimal condition. By cleaning independently, users have direct control over the quality and type of cleaning materials used. The mechanic can choose cleaning products that suit the specific needs of their vehicle [17].

Based on the results of testing the 4-channel injector cleaner and tester design using ultrasonic waves, the components used can function properly despite minor issues such as construction. From the data obtained from testing the 4-channel injector cleaner using ultrasonic waves, it can be said that the results are good because all four injectors received excellent test results.

The results of the design of the 4-channel injector cleaner and tester using ultrasonic waves show that cleaning using a DA-968 cleaner ultrasonic wave device with injector cleaner fluid is very important to reduce or clean deposits in the injector components [18]. For the electrical design, it has a 220-volt AC current to power the ultrasonic wave cleaner, as well as a 12-volt DC power supply to power the fuel pump and supply electricity to the injector. With the creation of the 4-channel injector cleaner and tester design using ultrasonic waves, it is hoped that the injector can be cleaned to the maximum extent possible.

4. CONCLUSION

Based on the design of the 4-channel injector cleaner and tester using ultrasonic waves, it can be concluded that this device makes it easier for users to clean injectors independently. By using the injector cleaner and ultrasonic waves of the DA-968 type, it is hoped that this device can clean injectors more effectively than manual methods or conventional cleaning tools. The results of this study indicate that the 4-channel injector cleaner using ultrasonic waves of type DA-968, with cleaning times of 3 minutes and 5 minutes, produced cloudy results. When testing the injector tester with a 1-minute cycle and a 3-minute cleaning cycle in the ultrasonic wave cleaner, out of the 4 injectors, 3 were found to be normal with a smooth and even cone-shaped spray, and 1 was weak with a smooth cone-shaped spray. Injector tester testing with a 1-minute cycle and a 5-minute cleaning process in the ultrasonic wave cleaner yielded results where all 4 injectors were normal with smooth and even cone-shaped spray patterns. Cleaning injectors with this device can be an effective and efficient solution for cleaning clogged injectors. Based on the design and testing results, the following recommendations can be made Students should be careful and meticulous when performing electrical connections to prevent short circuits in the injector electrical system, ultrasonic cleaner, and fuel pump. The dimensions of the 4-channel injector cleaner and tester designed using ultrasonic waves of type DA-968 were created and designed according to the requirements.

REFERENCES

- [1] H. Usui, T. Ishibashi, H. Matsuo, K. Watanabe, and K. Ando, "Visualization of acoustic waves and cavitation in ultrasonic water flow," *Solid State Phenom.*, vol. 314, pp. 186–192, 2021, doi: 10.4028/www.scientific.net/SSP.314.186.
- [2] X. Shi, H. Xu, and L. Yang, "Removal of formation damage induced by drilling and completion fluids with combination of ultrasonic and chemical technology," *J. Nat. Gas Sci. Eng.*, vol. 37, pp. 589–598, 2017, doi: 10.1016/j.jngse.2016.11.062.
- [3] H. Lais, P. S. Lowe, T. H. Gan, and L. C. Wrobel, "Numerical modelling of acoustic pressure fields to optimize the ultrasonic cleaning technique for cylinders," *Ultrason. Sonochem.*, vol. 45, pp. 78–87, 2018, doi: 10.1016/j.ultsonch.2018.02.045.
- [4] V. Morkun and O. Kravchenko, "Evaluation of ultrasonic cleaning process," *Nauk. Visnyk Natsionalnoho Hirnychoho Univ.*, no. 3, pp. 117–124, 2021, doi: 10.33271/nvngu/2021-3/117.
- [5] D. Radziuk and H. Mohwald, "Ultrasonically treated liquid interfaces for progress in cleaning and separation processes," *Phys. Chem. Chem. Phys.*, vol. 18, no. 1, pp. 30–46, 2016, doi: 10.1039/c5cp05142h.
- [6] X. Huang, Q. X. Wang, A. M. Zhang, and J. Su, "Dynamic behaviour of a two-microbubble system under ultrasonic wave excitation," *Ultrason. Sonochem.*, vol. 43, pp. 45–56, 2018, doi: 10.1016/j.ultsonch.2018.01.012.
- [7] A. V. Dengaev et al., "Chemical viscosity reduction of heavy oil by multi-frequency ultrasonic waves with the main harmonics of 20–60 kHz," *Fluids*, vol. 8, no. 4, p. 136, 2023, doi: 10.3390/fluids8040136.
- [8] M. Ehsani, H. Doan, and A. Lohi, "A comprehensive review of membrane fouling and cleaning methods with emphasis on ultrasound-assisted fouling control processes," *Korean J. Chem. Eng.*, vol. 38, no. 8, pp. 1347–1365, 2021, doi: 10.1007/s11814-021-0832-2.
- [9] K. Przybysz, A. Lipkiewicz, E. Małachowska, M. Dubowik, and P. Przybysz, "Assessment of efficiency and anilox-roll condition after ultrasonic cleaning," *Coatings*, vol. 13, no. 10, p. 1699, 2023, doi: 10.3390/coatings13101699.
- [10] R. Park et al., "Root canal irrigation system using remotely generated high-power ultrasound," *Ultrason. Sonochem.*, vol. 90, p. 106168, 2022, doi: 10.1016/j.ultsonch.2022.106168.
- [11] D. Chen, L. K. Weavers, and H. W. Walker, "Ultrasonic control of ceramic membrane fouling by particles: Effect of ultrasonic factors," *Ultrason. Sonochem.*, vol. 13, no. 5, pp. 379–387, 2006, doi: 10.1016/j.ultsonch.2005.07.004.
- [12] R. Zhang, Y. Huang, C. Sun, L. Xiaozhen, X. Bentian, and Z. Wang, "Study on ultrasonic techniques for enhancing the separation process of membrane," *Ultrason. Sonochem.*, vol. 55, pp. 175–183, 2019, doi: 10.1016/j.ultsonch.2018.12.041.
- [13] A. Amiri Delouei, H. Sajjadi, and G. Ahmadi, "Ultrasonic vibration technology to improve the thermal performance of CPU water-cooling systems: Experimental investigation," *Water*, vol. 14, no. 24, p. 4000, 2022, doi: 10.3390/w14244000.
- [14] G. Zhu et al., "Mechanism and application of laser cleaning: A review," *Opt. Lasers Eng.*, vol. 157, p. 107130, 2022, doi: 10.1016/j.optlaseng.2022.107130.
- [15] M. U. Khan, F. Rehman, M. Saleem, H. Elahi, T. H. Sung, and H. Jabbar, "Optimum driving of ultrasonic cleaner using impedance and FFT analysis with validation of image processing of perforated foils," *Appl. Sci.*, vol. 13, no. 12, p. 6991, 2023, doi: 10.3390/app13126991.
- [16] S. A. Aktij, A. Taghipour, A. Rahimpour, A. Mollahosseini, and A. Tiraferri, "A critical review on ultrasonic-assisted fouling control and cleaning of fouled membranes," *Ultrasonics*, vol. 108, p. 106228, 2020, doi: 10.1016/j.ultras.2020.106228.
- [17] T. Yamashita and K. Ando, "Low-intensity ultrasound induced cavitation and streaming in oxygen-supersaturated water: Role of cavitation bubbles as physical cleaning agents," *Ultrason. Sonochem.*, vol. 52, pp. 531–541, 2019, doi: 10.1016/j.ultsonch.2018.11.025.
- [18] F. Yuan, X. Zhao, Z. Wu, Y. Ding, and Q. Yang, "Washing performance of microbubbles on porous media," *J. Water Process Eng.*, vol. 58, p. 104761, 2024, doi: 10.1016/j.jwpe.2023.104761.